



Your PDF Guides

You can read the recommendations in the user guide, the technical guide or the installation guide for KONICA MINOLTA BIZHUB C352. You'll find the answers to all your questions on the KONICA MINOLTA BIZHUB C352 in the user manual (information, specifications, safety advice, size, accessories, etc.). Detailed instructions for use are in the User's Guide.

User manual KONICA MINOLTA BIZHUB C352
User guide KONICA MINOLTA BIZHUB C352
Operating instructions KONICA MINOLTA BIZHUB C352
Instructions for use KONICA MINOLTA BIZHUB C352
Instruction manual KONICA MINOLTA BIZHUB C352



KONICA MINOLTA

bizhub 750/600

Facsimile operations

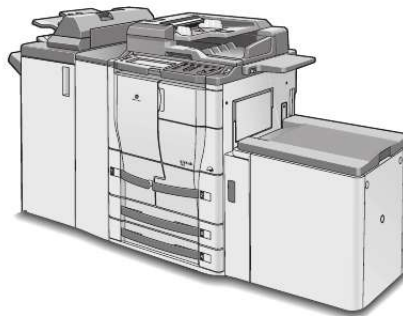

The essentials of imaging



[You're reading an excerpt. Click here to read official KONICA MINOLTA BIZHUB C352 user guide](http://yourpdfguides.com/dref/588603)
<http://yourpdfguides.com/dref/588603>

Manual abstract:

S.A. @@@@1-5 For Europe

.....
.....
.....

.....
.....
.....

.....
.....
.....

..... 1-6 Getting Started (FAX) ...

.....
.....
.....

.....
.....
.....

..... 1-7 Features of the FAX ..

.....
.....
.....

.....
.....
.....

.....
.....
.....

.. 1-9 How to Use This User's Guide

.....
.....
.....

.....
.....

.. 1-17 Descriptions and Symbols for Documents and Paper ...

.....

... 1-18 "Width" and "Length"

.....
.....
.....

.....
.....
.....

1-18 Paper Orientation

.....
.....

.....
.....
.....
.....

.....
.....
.....
.....
... 1-18 User's Guides

.....
.....
.....
.....
.....
.....
.....

.....
.....
1-19 2 Before Use 2.1 2.2 2.2.1 2.3 2.3.1 2.4 2.4.1 2.4.2 2.5 2.6 2.6.1 2.6.2 2.7 2.7.1 2.7.2 2.7.3

3 Restriction matter

.....
.....
.....
.....
.....

.....
.....
.....
..... 2-2 Control Panel ...

.....
.....
.....
.....
.....
.....

.....
.....
.....
. 2-3 Control Panel

.....
.....
.....
.....
.....
.....

.....
.. 2-3 First-Use Settings ...

.....
.....

.....
.....
.....

.....
.....
.....

..... 2-6 Must-Set Items .

.....
.....
.....

.....
.....
.....

.....
.....

... 2-6 Useful Functions ..

.....
.....
.....
.....

.....
.....
.....

..... 2-7 Address Book ...

.....
.....
.....

.....
.....
.....

.....
.....

..... 2-7 Program @@2-11 FAX Screen ...

.....
.....
.....

.....
.....
.....

.....
.....
.....

... 2-14 User Authentication and Account Track

.....
.....
.....
.....

. 2-16 When the User Authentication has been set

.....
.....
.....

... 2-16 When the Account Track has been set

.....
.....
.....

... 2-16 Fax reception using the Box ..

.....
.....
.....
.....
.....
.....

. 2-17 Type of boxes (With hard disk installed)

.....
.....

.... 2-18 Type of boxes (with no hard disk installed) .

.....

... 2-20 Operations of the PC-FAX RX feature

.....
.....
.....
.....

..... 2-21 i bizhub 750/600 Table of contents 3 Transmission 3.1 3.2 3.2.1 3.

2.2 3.2.3 3.2.

4 3.3 3.3.1 3.3.

2 3.3.3 3.3.4 3.3.5 3.3.6 3.4 3.

4.1 3.4.2 3.4.3 3.4.4 3.5 3.5.

1 3.5.2 3.5.3 3.

6 3.7 3.8 3.9 3.9.

1 3.9.2 3.10 3.11 3.12 3.13 Simple FAX Transmission

.....
.....
.....
.....

.....
.....
.....
.....

.3-2 Placing the Original on the Machine

.....
.....
.....

.....3-5 Using the ADF .

.....
.....
.....
.....
.....
.....
.....
.....

3-5 Placing Originals on the Platen Glass

.....
.....
.....
.....

.....3-6 Sending Multiple Originals from the Platen Glass

.....
.....
.....

.3-6 Transmitting Originals by Using both the ADF and the Platen Glass

.....
.....
.....
.....

.....3-8 Setting Transmission Conditions

.....
.....
.....

.....3-10 Original Image Type

.....
.....
.....
.....

.....3-11 Density ...3-11 Simplex/Duplex ..

.....
.....
.....
.....
.....
.....

.....
.....
.....
.....
.....
.....3-12 Resolution

.....
.....
.....
.....

.....
.....
.....
.....

.....
.....
.....

3-12 Confirming Settings and Communication Results

.....
...3-14 Registering the Address Book from the Mode Check screen .

.....
3-17 Selecting One Destination

.....
.....
.....
.....

.....
.....
.....

..3-19 Selecting One Destination

.....
.....
.....
.....

.....
.....
.....

..3-19 Selecting Multiple Destinations

.....
.....
.....
.....

.....
....3-25 To Confirm/Delete a Destination .

.....
.....

.....
.....
.....
.....

.....3-26 Manual Redialing

.....
.....
.....

.....
.....
.....
.....

.....
.....
.....3-27 Scanning .

...3-28 When Original Size Cannot be Detected

.....
.....
.....
.....

.3-28 When Memory Capacity is Exceeded

.....
.....
.....

.....
.....3-28 Automatic rotation of original document .

.....
.....

.....
.....
.....

..3-28 When Unable to Send

.....
.....
.....
.....
.....
.....
.....
.....

..3-29 Reserving Transmission

.....
.....
.....
.....
.....
.....
.....

.....3-30 Manual Transmission ...

.....
.....
.....
.....
.....
.....
.....

.....
.....
.....3-31 Canceling Transmission ...

.....
.....
.....
.....

.....
.....
.....
.....
.....
.....
..3-32 Canceling Communication in Progress

.....
.....
.....
.....
.....
.....
..3-32 Canceling Reserved Jobs

.....
.....
.....
.....
.....
.....
...3-33 Confirm the Job List

.....
.....
.....
.....
.....
.....
.....
.....
.....
.....
3-34 Confirming Communication Results

.....
.....
.....
.....
.....
.....
.....
.....
.....
.....
3-35 Timer Transmission

.....
.....
.....
.....
.....
.....
.....
.....
.....
.....
...3-38 International Communication ..

.....
.....
.....
.....
.....
.....
.....
.....
3-40 ii bizhub 750/600 Table of contents 3.14 3.14.1 3.14.2 3.14.3 Sender Information ...
.....

.....
.....
.....
.....
.....
.....
.....
.....

3-42 Set to Inside Body Text

.....
.....
.....
.....
.....
.....

.... 3-42 Set to Outside Body Text

.....
.....
.....
.....
.....
.....

..... 3-42 Set to OFF

.....
.....
.....
.....
.....
.....
.....
.....
.....
.....

..... 3-43 4 Reception 4.

1 4.1.1 4.1.2 4.2 4.3 4.4 4.5 4.6 4.

6.1 4.6.2 4.6.

3 4.7 Reception Mode

.....
.....
.....
.....
.....
.....
.....
.....

..... 4-2 Auto Reception (FAX Only Mode)

.....
.....
.....
.....

.....
.....
.....
..... 4-2 Manual Reception (Telephone Only Mode)

.....
.....
.....
.....

.. 4-2 Auto Reception (FAX Only Mode)

.....
.....
.....

.....
.....
.....

.... 4-3 Manual Reception (Telephone Only Mode)

.....
.....
.....
.....

4-4 Unable to Receive

.....
.....
.....

.....
.....
.....
.....

.....
.....
.....

.. 4-5 Memory Substitute Reception ...

.....
.....

.....
.....
.....

.... 4-6 Reception Recording .

.....
.....

.....
.....
.....

.....
.....
.....

..... 4-7 Recording after Reducing at the Minimum Reduction Rate

..... 4-7 Recording after Reducing to Fit in Paper

.....
.....
.....

.... 4-8 Recording at Full Scale .

.....

.....

.....

.....

.....

.....

.....

.....

... 4-14 Reception Information ..

.....

.....

.....

.....

.....

.....

.....

..... 4-16 5 Troubleshooting 5.1 5.2 5.3 5.4 Cannot Send Messages .

.....

.....

.....

.....

.....

.....

.....

..... 5-2 Cannot Receive Messages

.....

.....

.....

.....

.....

.....

..... 5-3 Error Message Displayed ..

.....

.....

.....

.....

.....

.....

.....

... 5-5 Call for Service ..

.....

.....

.....

.....

.....

.....

.....

.....

.....

..... 5-6 6 Specifications 6.1 Specifications

.....
.....
.....

.....
.....
.....
.....

.....
.....
.....

..... 6-2 7 Transmission Applications 7.

1 7.2 7.3 7.4 7.5 7.6 Opening the Scan Setting Screen and Comm. Setting screen
7-2 Application Functions Overview

.....
.....

.....
.....
.....
.....

.... 7-4 Mixed Original

.....
.....
.....

.....
.....
.....
.....

.....
.....
.....

..... 7-6 Z-Folded Original ...

.....
.....
.....
.....

.....
.....
.....
.....

.....
.....
.....

7-9 Long Original

.....
.....
.....

.....
.....
.....
.....

.....
.....
.....

..... 7-12 Bind Position ..

.....

.....
.....
.....
.....
.....
.....
.....
.....
.....
.....

. 7-15 bizhub 750/600 iii Table of contents 7.7 7.8 7.9 7.10 7.11 7.12 7.13 7.13.
1 7.14 7.15 7.16 Frame Erase Transmission ..

.....
.....
.....
.....
.....

....7-18 Background Adjustment .

.....
.....
.....
.....
.....

....7-21 TX Stamp .

..7-24 Scan Size ...7-27 Specify the File Type

.....
.....
.....
.....
.....
.....
.....

.....7-30 Password Transmission

.....
.....
.....
.....
.....

..7-32 Confidential Communication (F-Code TX) ...

.....
.....
.....
.....

...7-34 Confidential Communication ..

.....

.....
.....
.....

....7-34 Relay Transmission Request (F-Code TX) .

.....
.....

.....
.....
.....

7-37 ECM OFF ...7-40 V.34 OFF7-42 8 Useful Functions for Reception 8.1 8.

1.1 8.1.2 8.1.3 8.2 8.2.1 8.2.

2 8.3 8.3.1 Utilize a document received as Confidential Reception ..

.....

.....8-2 Utilize a document received as Confidential Reception .

.....
.....

.8-2 Printing the Document Received in a Confidential User Box

....8-3 Deleting Documents from a Confidential User Box

.....
.....

....8-4 Memory Reception .

.....

.....
.....
.....

.....
.....
.....

....8-5 Printing a Document Held in Memory

.....
.....
.....

.....
.....
.....

8-5 Deleting a Document Held in Memory

.....
.....
.....

....8-7 Reception Information

.....
.....
.....

.....
.....
.....

.....

....8-8 Various Reception Information .

.....
.....

.....
.....
.....

.....8-8 9 Polling 9.

1 9.1.1 9.2 9.3 9.

3.1 9.3.2 Polled Transmission ..

.....

.....
.....
.....

.....
.....
.....

..9-2 Polled Transmission

.....
.....
.....

.....
.....
.....

....9-2 Polling Reception .

.....
.....

.....
.....
.....

.....
.....
.....

..9-5 Bulletin

.9-8 Write a Document to the Bulletin Board

.....
.....

.....
.....

..9-9 Receive by Polling a Document Written to the Bulletin Board of a Destination (FAX)

.....
.....
.....

....9-11 iv bizhub 750/600 Table of contents 10 Registering/Settings 10.1 10.2 10.3 10.4 10.5 10.

6 10.7 10.8 Displaying the Fax Registration Screen

.....
.....

.....
.....
. 10-2 Registering the Address Book
.....
.....

..... 10-3 Registering the Group

.....
.....
.....

.....
.....
. 10-16 Registering the Program

.....
.....
.....

.....
.....
... 10-22 Registering the Subject and Text of the E-Mail ..

.....
.....

..... 10-28 Setting Up Confidential Reception (F-Code RX) User Boxes ..

. 10-42 Setting the Bulletin Board

.....
.....
.....

.....
.....
. 10-48 Setting the Memory RX User Box

.....
.....
.....

..... 10-49 11 Utility Mode 11.1 11.

1.1 11.1.2 11.1.3 11.1.4 11.2 11.2.

1 11.2.2 11.2.3 11.

2.4 11.2.5 11.2.

6 11.2.7 11.2.8 11.2.9 11.2.10 11.2.

11 11.2.12 11.2.13 Utility Mode Screen

.....
.....
.....

.....
.....
.....
.....

. 11-2 Entering User Setting ...

.....
.....
.....
.....

... 11-2 Exiting from User Setting

.....
.....
.....
.....

.... 11-2 Entering Administrator Setting

.....
.....
.....
.....

.. 11-3 Exiting from Administrator Setting ...

.....
.....
.....
.....

.... 11-4 FAX Utility Mode List

.....
.....
.....
.....
.....
.....

.... 11-5 User Setting >&.

.....
.....
.....

.....12-4 TX Report ..12-7 Manual Printout ...

.....
.....

.....
.....

.....
.....
.....

.....
.....
....12-7 Automatic Printout .

.....
.....
.....
.....

.....
.....
.....12-7 Polling TX Report

.....
.....
.....
.....
.....
.....

.....
...12-9 Polling RX Report ..

.....
.....
.....
.....

.....
.....
.....12-11 vi bizhub 750/600 Table of contents 12.6 12.7 12.

8 12.9 Broadcast Report

.....
.....
.....
.....
.....

.....
.... 12-13 Sequence Polling Reception Report .

.....
.....
.....

..... 12-15 Reservation Communication Report ...

.....
.....
.....
.....

..... 12-17 Reservation Polling TX Report .

.....
.....
.....

.....
.....
.....
.....

. 12-19 12.10 Broadcast Reserved Report

.....
.....
.....

.....
.....
.....

..... 12-21 12.11 An address Polling Rx Reserved Report .

.....
.....
.....
.....

..... 12-23 12.12 Sequence Polling RX Reservation Report

.....
.....
.....

.....
12-25 12.13 Confidential RX Report

.....
.....
.....

.....
.....
.....
.....

.....
12-27 12.14 Bulletin TX Report

.....
.....
.....

.....
.....
.....

.....
.....
.....

..... 12-29 12.

15 Address Book List

.....
.....
.....
.....

.....
.....
.....

.....
.. 12-31 12.16 Group Address List ..

.....
.....

.....
.....
.....
.....

.....
.....
.....

.... 12-34 12.17 Program List

.....
.....
.....
.....

.....
.....
.....
.....

.....
.....

.. 12-37 12.18 E-Mail Subject/Text List ..

.....

.....
.....
.....
.....

.....
.....
.....

. 12-40 12.19 Fax Setting List

.....
.....
.....
.....

.....
.....
.....
.....

..... 12-43 12.

19.1 12.19.2 Confidential/Bulletin List ..

.....
.....

.....
.....
.....
.....

.....
.....

... 12-47 Sender (TSI) RX Box ..

.....

.....
.....
.....
.....
.....

.... 12-48 13 Appendix 13.

1 13.2 13.3 13.4 Number of Stored Pages to Memory

.....
.....
.....
.....

..... 13-2 Entering Text ...

.....
.....
.....

.....
.....
.....

.....
.....
.....
.....

13-3 FAX Terms @@13-6 Index 13-12 bizhub 750/600 vii 1 Introduction Introduction Chapter 1 1 Chapter 1 Introduction 1 Introduction Thank you for your purchase of our product. This User's Guide describes operating procedures and precautions for use of the Fax functions. Please read this User's Guide before starting operation of the machine.

After reading this User's Guide, it is advisable to keep it close at hand to consult it any time when necessary in order to operate the Fax functions at their optimum condition. For correct operation, also read the "User's Guide (Copy Operations)" before starting operation. **ACKNOWLEDGEMENT:** KONICA MINOLTA, KONICA MINOLTA Logo, and The essentials of imaging are registered trademarks or trademarks of KONICA MINOLTA HOLDINGS, INC. PageScope and bizhub are registered trademarks or trademarks of KONICA MINOLTA BUSINESS TECHNOLOGIES, INC. Adobe, Adobe Logo, Acrobat, Acrobat Logo, PostScript and PostScript Logo are registered trademarks or trademarks of Adobe Systems, Inc.

Other company names and product names used in this User's Guide are the registered trademarks or trademarks of their respective companies.



[You're reading an excerpt. Click here to read official KONICA MINOLTA BIZHUB C352 user guide](http://yourpdfguides.com/dref/588603)
<http://yourpdfguides.com/dref/588603>

COPYRIGHT © 2006 by KONICA MINOLTA BUSINESS TECHNOLOGIES, INC. All Rights Reserved. EXEMPTION A part or this User's Guide may be used or duplicated without permission. Information written in this User's Guide is subject to change without notice.

Introduction 1-2 bizhub 750/600 Introduction 1 Chapter 1 1-3 1.1 1.1.1 Special Notice to User For Canada NOTICE: This product meets the applicable Industry Canada technical specifications. The Ringer Equivalence Number is an indication of the maximum number of devices allowed to be connected to a telephone interface. The termination on an interface may consist of any combination of devices subject only to the requirement that the sum of the RENs of all the devices does not exceed five. AVIS: Le present materiel est conforme aux specifications techniques applicables d'Industrie Canada. L'indice d'equivalence de la sonnerie (IES) sert a indiquer le nombre maximal de terminaux qui peuvent etre raccordes a une interface telephonique. La terminaison d'une interface peut consister en une combinaison quelconque de dispositifs, a la seule condition que la somme d'indices d'equivalence de la sonnerie de tous les dispositifs n'excede pas 5. 1.

1.2 For U.S.A. FCC PART 68 REQUIREMENTS: This equipment complies with Part 68 of the FCC rules and the requirements adopted by the ACTA. On the cover of this equipment is a label that contains, among other information, a product identifier in the format US:AAAEQ##TXXXX. If required, this information must be provided to the telephone company. This equipment uses certification jack USOC RJ11C. A plug and jack used to connect this equipment to the premises wiring and telephone network must comply with the applicable FCC Part 68 rules and requirements adopted by the ACTA. A compliant telephone cord and modular plug is provided with this product.

It is designed to be connected to a compatible modular jack that is also compliant. See installation instructions for details. The REN is used to determine the number of devices that may be connected to a telephone line. Excessive RENs on a telephone line may result in the de- bizhub 750/600 Introduction 1 Chapter 1 Introduction vices not ringing in response to an incoming call. In most but not all areas, the sum of RENs should not exceed five (5).

0). To be certain of the number of devices that may be connected to a line, as determined by the total RENs, contact the local telephone company For products approved after July 23, 2001, the REN for this product is part of the product identifier that has the format US:AAAEQ##TXXXX.. The digits represented by ## are the REN without a decimal point (e.g.

, 03 is a REN of 0.3). For earlier products, the REN is separately shown on the label. Introduction If this equipment FK-502 causes harm to the telephone network, the telephone company will notify you in advance that temporary discontinuance of service may be required. But if advance notice isn't practical, the telephone company will notify the customer as soon as possible. Also, you will be advised of your right to file a complaint with the FCC if you believe it is necessary. The telephone company may make changes in its facilities, equipment, operations or procedures that could affect the operation of the equipment. If this happens the telephone company will provide advance notice in order for you to make necessary modifications to maintain uninterrupted service. If trouble is experienced with this equipment FK-502, for repair or warranty information, please contact the Konica Minolta dealer location where you purchased this equipment. If the equipment is causing harm to the telephone network, the telephone company may request that you disconnect the equipment until the problem is resolved.

Connection to party line service is subject to state tariffs. Contact the state public utility commission, public service commission or corporation commission for information. If you home has specially wired alarm equipment connected to the telephone line, ensure the installation of FK-502 does not disable you alarm equipment. If you have questions about what will disable alarm equipment, consult your telephone company or a qualified installer. The Telephone

Consumer Protection Act of 1991 makes it unlawful for any person to use a computer or other electronic device, including FAX machines, to send any message unless such message clearly contains in a margin at the top or bottom of each transmitted page or on the first page of the transmission, the date and time it is sent and an identification of the business or other entity, or other individual sending the message and the telephone number of the sending machine or such business, other entity, or individual. 1-4 bizhub 750/600 Introduction 1 Chapter 1 Introduction (The telephone number provided may not be a 900 number or any other number for which charges exceed local or long-distance transmission charges.) In order to program this information into your FAX machine, you should complete the following steps: See "Header Information" on page 11-20. WARNING/CAUTION Explained WARNING The exclamation point within an equilateral triangle followed by the word "Warning" is intended to alert the user to the possibility that a disregard for the warning may result in fatal hazards or critical injuries. Be sure to focus your attention on the Warning headings when reading the Copier User's Guide. CAUTION The exclamation point within an equilateral triangle followed by the word "Caution" is intended to alert the user to the possibility that a disregard for the caution may result in minor injuries or in physical damage.

Be sure to focus your attention on the Caution headings when reading the Copier User's Guide. 1.1.3 For New Zealand 1. This device is equipped with pulse dialing while the Telecom standard is DTMF tone dialing.

There is no guarantee that Telecom lines will always continue to support pulse dialing. 2. Use of pulse dialing, when this equipment is connected to the same line as other equipment, may give rise to bell tinkle or noise and may also cause a false answer condition. Should such problems occur, the user should not contact the Telecom Fault Service. 3.

This equipment may not provide for the effective hand-over of a call to another device connected to the same line. 4. This equipment does not fully meet Telecom's impedance requirements. Performance limitations may occur when used in conjunction with some parts of the network. Telecom will accept no responsibility should difficulties arise in such circumstances. 5. The grant of a Telepermit for any item of terminal equipment indicates only that Telecom has accepted that the item complies with minimum conditions for connection to its network. It indicates no endorsement of the product by Telecom, nor does it provide any sort of warranty. Above all, it provides no assurance that any item will work correctly in all respects with another item of Telepermitted equipment of a different make or model, nor does it imply that any product is compatible with all of Telecom's network services.



[You're reading an excerpt. Click here to read official KONICA MINOLTA BIZHUB C352 user guide](http://yourpdfguides.com/dref/588603)
<http://yourpdfguides.com/dref/588603>

The automatic calling functions of this equipment must not be used to cause a nuisance to other customers. bizhub 750/600 1-5 1 Chapter 1 Introduction 7.

Telepermitted equipment only may be connected to the auxiliary telephone port. The auxiliary port is not specifically designed for 3-wire connected equipment. 3-wire might not respond to incoming ringing when connected to this port. Introduction 1.1.4 For Europe The Facsimile has been approved in accordance with Council Decision 1999/ 5/ EC for pan-European single terminal connection to the public switched telephone network (PSTN). However, due to differences between the individual PSTNs provided in different countries, the approval does not, of itself, give an unconditional assurance of successful operation on every PSTN network terminal point. In the event of problems, you should contact your equipment supplier in the first instance.

The CE marking must be affixed to the product or to its data plate. Additionally it must be affixed to the packaging, if any, and to the accompanying documents. 1-6 bizhub 750/600 Introduction 1 Chapter 1 1-7 1.2 Getting Started (FAX) Sending Perform the following basic procedure to send a FAX. 1 2 Press [Fax] on the control panel to start the FAX mode.

Set the functions as necessary. FAX screen Scan Setting screen Application screen Comm. Setting screen bizhub 750/600 Introduction 1 Chapter 1 Introduction 3 Use the keypad to enter the FAX number of the destination. If you make an incorrect entry, press [Del.] to clear your entry.

Press [C] (clear) to clear the whole entry. Box Access Fax Scan Copy Reset ABC DEF Interrupt Power GHI JKL MNO Mode Memor Memory Utility/ Counter Mode Chec Check PQRS TUV WXYZ Proof Copy Introduction Stop Start Star Data Main Power P er 4 Place the original on the machine. For details, see "Placing the Original on the Machine" on page 3-5. 5 Press [Start] on the control panel. Box Access Fax Scan Copy Reset ABC DEF Interrupt Power GHI JKL MNO Mode Memor Memory Utility/ Counter Mode Chec Check PQRS TUV WXYZ Proof Copy Stop Start Star Data Main Power P er 1-8 bizhub 750/600 Introduction 1 Chapter 1 1-9 1.3 Features of the FAX Send a FAX at a specified time This function allows you to specify the time to start sending a fax. You can save money by specifying a transmission to start during the night or early in the morning when telephone charges are less. ! Detail For details, see "Timer Transmission" on page 3-38. Sending faxes to a foreign country You can employ a lower transmission rate if you send a FAX to the location at which the communication condition is poor. ! Detail For details, see "International Communication" on page 3-40.

bizhub 750/600 Introduction 1 Chapter 1 TX Stamp Introduction When transmitting a fax via the copier's ADF, a stamp can be affixed to the pages of the document that have already been scanned, allowing you to confirm that these pages have been scanned. Introduction Front surface of original document Original document transmitting direction Stamp position ! Detail For details, see "TX Stamp" on page 7-24. Frame erasure mode You can send a FAX by erasing dark bands sometimes created when transmitting a document bound in the form of book. You can also set the width of marginal erasure according to your preference. ! Detail For details, see "Frame Erase Transmission" on page 7-18. 1-10 bizhub 750/600 Introduction Send a FAX in original size select mode 1 Chapter 1 Introduction You can send a FAX by designating the paper size for the document to be sent. It is useful if you want to send only a portion of the original. ! Detail For details, see "Scan Size" on page 7-27. Setting and sending document pages of mixed sizes in a single operation You can send pages of mixed sizes because the facsimile recognizes each size and sends pages properly when the mixed original feature is used. Transmitted and reproduced in the same sizes as the original pages at the destination.

You set document pages of mixed sizes on the ADF. ! Detail For details, see "Mixed Original" on page 7-6. bizhub 750/600 1-11 1 Chapter 1 Send Z folded original Introduction You can send Z folded original because the ADF can determine the document size properly. Some facsimiles cannot detect the document size if it has been folded. Introduction ! Detail For details, see "Z-Folded Original" on page 7-9.

Sending long originals You can send originals longer than 432 mm. ! Detail For details, see "Long Original" on page 7-12. 1-12 bizhub 750/600 Introduction Specify the binding style of a two-sided document 1 Chapter 1 Introduction You can specify the appropriate binding style when transmitting two-sided documents. Binding style allows the pages of the document to be read appropriately by determining right to left or top to bottom. ! Detail For details, see "Bind Position" on page 7-15.

Sending a FAX when it receives a polling command from the recipient You can send a FAX that has been read and stored in hard disk in the facsimile when a polling command is sent from the recipient. ! Detail For details, see "Polling Reception" on page 9-5. Sending a FAX with ECM disabled You can send a FAX with ECM disabled to shorten the transmission time. ! Detail For details, see "ECM OFF" on page 7-40. bizhub 750/600 1-13 1 Chapter 1 Polling specified document Introduction You can store documents that you want to poll in the bulletin board of the hard disk for polling transmission or polling reception. Introduction ! Detail For details, see "Bulletin" on page 9-8. Sending a FAX with the Super G3 mode disabled You can send a FAX with the super G3 mode disabled if V.34 protocol is not available because of restrictions on the Private Branch Exchange (PBX). ! Detail For details, see "V.34 OFF" on page 7-42.

Relay Fax You can send a FAX to a recipient via an intermediate relay station. Remote Station Original Station Intermediate relay station Local call Toll call Remote Station ! Detail For details, see "Relay Transmission Request (F-Code TX)" on page 7-37. This machine is not provided with a relay delivery function. 1-14 bizhub 750/600 Introduction Use a confidential box 1 Chapter 1 Introduction 1-15 You can use a confidential box (similar to an inbox) to exchange confidential information with specific person. Sender Classified Document Box Receiver ! Detail For details, see "Confidential Communication (F-Code TX)" on page 7-34.



[You're reading an excerpt. Click here to read official KONICA MINOLTA BIZHUB C352 user guide](http://yourpdfguides.com/dref/588603)
<http://yourpdfguides.com/dref/588603>

Sending a FAX protected with a password You can send a FAX protected with a password if the closed communication is set at the recipient. ! Detail For details, see "Password Transmission" on page 7-32. To be sent with the density in the background color adjusted. Transmission can be made after the density in the background color of the original is adjusted. ! Detail For details, see "Background Adjustment" on page 7-21.

bizhub 750/600 1 Chapter 1 An E-Mail is sent from the fax screen. Introduction An original that has been read can be sent as an E-Mail from the fax screen to the computer. Mail Server Introduction E-Mail ! Detail For details, see "Direct Input" on page 3-23. To be saved in the box. An original that has been read can be saved in the box.

BOX Hard Disk ! Detail If the main power supply is turned OFF when the optional hard disk is not used, the information of the box is erased. Contact the service representative for the optional hard disk. For details, see "Fax reception using the Box" on page 2-17. 1-16 bizhub 750/600 Introduction 1 Chapter 1 3 3-31 1.4 How to Use This User's Guide Title Transmission 3.

10 Confirming Reserved Documents Confirming Reserved Documents Transmission reservation documents stored in memory can be confirmed on the job list screen. 1 Press [JOB LIST] on the FAX Basic screen. Shows the view of the touch screen at the operation. 7 Warning 7WARNING Failure to observe instructions highlighted in this manner may result in fatal or critical injuries. Observe all warnings in order to ensure safe use of the machine. 7CAUTION Failure to observe instructions highlighted in this manner may result in serious injuries or property damage. Observe all cautions in order to ensure safe use of the machine. WARNING % % % Failure to observe instructions highlighted in this manner may result in fatal or critical injuries. Observe all warnings in order to ensure safe use of the machine. Caution 2.

.. Reminder Text highlighted in this manner indicates operation precautions. Carefully read and observe this type of information. ! Detail Text highlighted in this manner provides more detailed information concerning operating procedures or references to sections containing additional information. If necessary, refer to the indicated sections. 2... Note Text highlighted in this manner contains references and supplemental information concerning operating procedures and other descriptions.

We recommend that this information be read carefully. bizhub 750/600 2... Reminder Text highlighted in this manner indicates operation precautions. Carefully read and observe this type of information. ! Detail Text highlighted in this manner provides more detailed information concerning operating procedures or references to sections containing additional information. If necessary, refer to the indicated sections. 2..

. Note Text highlighted in this manner contains references and supplemental information concerning operating procedures and other descriptions. We recommend that this information be read carefully. This page does not exist in the document. bizhub 750/600 1-17 Introduction [] Names highlighted as shown above indicate keys on the control panel and keys in the touch panel. 1 Chapter 1 Introduction 1.5 1.5.1 Descriptions and Symbols for Documents and Paper The use of words and symbols in this manual are explained below. "Width" and "Length" Whenever paper dimensions are mentioned in this manual, the first value always refers to the width of the paper (shown as "Y" in the illustration) and the second to the length (shown as "X").

Introduction 1.5.2 Paper Orientation Lengthwise (w) If the width (Y) of the paper is shorter than the length (X), the paper has a vertical or portrait orientation, indicated by w. Crosswise (v) If the width (Y) of the paper is longer than the length (X), the paper has a horizontal or landscape orientation, indicated by v. 1-18 bizhub 750/600 Introduction 1 Chapter 1 1-19 1.6 User's Guides The following User's Guides have been prepared for this machine. User's Guide [Copy Operations] This manual contains details on basic operations and the operating procedures for the various copy functions. - Refer to this User's Guide for details on operating procedures for copy functions, including precautions on installation/use, turning the machine on/off, loading paper, and troubleshooting operations such as clearing paper misfeeds. Furthermore and this manual contains details on the setting method of the customize for using usually, and the management method of a machine. - Refer to this User's Guide for details on the setting method of a paper, the adjustment method of a tray, the setting method of a machine and the method of management of a machine.

User's Guide [Network Scanner Operations] This manual contains details on specifying network settings for standard equipment and on operations for scanning functions. - Refer to this User's Guide for details on operating procedures for network functions and for using Scan to E-Mail, Scan to FTP and Scan to SMB. User's Guide [Box Operations] This manual contains details on operating procedures for using the boxes. - Refer to this User's Guide for details on operating procedures for using the boxes on the hard disk. User's Guide [Enlarge Display Operations] This manual contains details on operating procedures for using copy functions in Enlarge Display mode.

- Refer to this User's Guide for details on operating procedures in Enlarge Display mode. User's Guide [Facsimile Operations] <this manual> This manual describes the operation of the FAX functions which can be used when the optional fax kit, FK-502, is installed. - Refer to this User's Guide for details on the operation of the FAX functions. bizhub 750/600 Introduction 1 Chapter 1 Introduction Furthermore, the following User's Guide (PDF)/Quick Guide have been prepared for this machine. IC-202 User's Guide/Quick Guide This manual contains details on operating procedures using the optional Image Controller (IC-202).

- Refer to the User's Guide (PDF data) provided in the User Software CDROM or Quick Guide (printed matter) attached to IC-202 for the procedures to use the printer functions. Introduction 1-20 bizhub 750/600 2 Before Use Before Use Chapter 2 2 2 Chapter 2 Before Use Before Use Restriction matter This fax kit can be connected to phone lines as shown below. - Local phone lines (including facsimile communication networks) - PBX (Private branch exchange Two wire system) With respect to the telephone line to be used, be sure to check the following. - A business phone cannot be connected as an outside line. - When the digital private line is multiplexed in the corporate network that is used by the customer, the facsimile communication may be subject to the following constraints.



[You're reading an excerpt. Click here to read official KONICA](http://yourpdfguides.com/dref/588603)

[MINOLTA BIZHUB C352 user guide](http://yourpdfguides.com/dref/588603)

<http://yourpdfguides.com/dref/588603>

The transmission speed is restricted. Communication by the Super G3 is not available. There may occur once in a while communication errors in the setting made when the product was shipped from the factory. These constraints are due to the multiplexed device that restricts the band available for the line to the utmost limit on the assumption that voice is used. However, these constraints vary depending on a device that makes up the network.

For more information, refer to the administrator of the network that you use. 2.1 Before Use 2 Reminder Turning the power OFF/ON repeatedly may cause an fault. After turning OFF the equipment, wait for more than 5 seconds before turning it ON again. 2-2 bizhub 750/600 Before Use 2 2.2 2.2.1 Control Panel Control Panel Chapter 2 10 11 2-3 1 2 3 4 5 6 7 23 22 21 20 No. 1 Name [Power Save] key 19 18 17 16 15 14 13 12 Description Press to enter Low Power mode. While the machine is in Low Power mode, the indicator on the [Power Save] key lights up in green and the touch panel goes off.

To cancel Low Power mode, press the [Power Save] key again. Displays various screens and messages. Specify the various settings by directly touching the panel. If user authentication or account track settings have been applied, press this key after entering the user name and password (for user authentication) or the account name and password (for account track) in order to use this machine. Press to enter Box mode.

While the machine is in Box mode, the indicator on the [Box] key lights up in green. For details, refer to the User's Guide (Box Operations). Press to enter Fax mode. While the machine is in Fax mode, the indicator on the [Fax] key lights up in green. Press to enter Scan mode.

While the machine is in Scan mode, the indicator on the [Scan] key lights up in green. For details, refer to the User's Guide (Network Scanner Operations).

Press to enter Copy mode. (As a default, the machine is in Copy mode.) While the machine is in Copy mode, the indicator on the [Copy] key lights up in green. For details, refer to the User's Guide (Copy Operations). 2 Touch panel 3 [Access] key 4 [Box] key 5 [Fax] key 6 [Scan] key 7 [Copy] key bizhub 750/600 Before Use 8 9 2 No. 8 9 Name [Reset] key [Interrupt] key Description Before Use Press to clear all settings (except programmed settings) entered in the control panel and touch panel. Press to enter Interrupt mode. While the machine is in Interrupt mode, the indicator on the [Interrupt] key lights up in green and the message "Now in Interrupt mode.

" appears on the touch panel. To cancel Interrupt mode, press the [Interrupt] key again. Stops reading the original. Press to start the operation that is selected Box mode, Fax mode, Scan mode or Copy mode. While in Fax mode, fax transmission is started. When this machine is ready to begin operation, the indicator on the [Start] key lights up in green. If the indicator on the [Start] key lights up in orange, operation cannot begin. Lights up in green when the machine is turned on with the main power switch. Flashes in green while a print job is being received. Lights up in green while a print job is queued to be printed or while it is printing.

Not used for Fax mode. Use to type in the number. Use to type in the telephone numbers and various set values. Press to erase a value entered using the keypad. Press to display screens showing the specified settings.

Press to display the Meter Count screen and the Utility screen. Not used for Fax mode. Use to adjust the contrast of the touch panel. Not used for Fax mode. Press to display the screen for specifying user accessibility functions.

Press to display the Help Main Menu screen, where descriptions of the various functions and details of operations can be displayed. For details, refer to User's Guide (Copy Operations). Chapter 2 10 [Stop] key [Start] key Before Use 11 12 13 Main Power indicator Data indicator 14 15 16 17 18 19 20 21 22 23 [Proof Copy] key Keypad [C] (clear) key [Mode Check] key [Utility/Counter] key [Mode Memory] key Contrast dial [Enlarge Display] key [Accessibility] key [Help] key 2-4 bizhub 750/600 Before Use 2 Reminder 2 Chapter 2 Before Use Do not apply extreme pressure to the touch panel, otherwise it may be scratched or damaged. Never push down on the touch panel with force, and never use a hard or pointed object to make a selection in the touch panel. When the screen instructing you to call your service representative appears and copying is no longer possible, a malfunction may have occurred. Note the malfunction code, immediately unplug the machine, and then contact the service representative to inform them of the malfunction code. bizhub 750/600 2-5 2 2.3 2.3.1 Chapter 2 Before Use First-Use Settings Must-Set Items After installation, you must set the following items to use the facsimile functions.

You will not be able to execute the FAX communication if these items are not set properly. - Header Information Registers the FAX number and name of this facsimile. - Telephone Line settings Sets the telephone line and the receiving method. Header Information Set the following items. Before Use ! Detail For details, see "Header Information" on page 11-20. Sender Name Set the name of this machine. The name is a string of up to 30 characters. The name can contain with any alphanumeric character and symbols. Set the FAX number of this machine. The FAX ID is a number of up to 20 digits.

The ID can contain any number between 0 and 9, the + symbol, spaces, * symbol, and # symbol. Sender Fax No. Telephone Line Settings Set the following items. ! Detail For details, see "Telephone Line Settings" on page 11-25. Dialing Method Receive Mode Select between tone dialing line and pulse dial line (PB, Pulse).

Select between automatic reception and manual reception. Select "Auto RX" for automatic reception. Select "Manual RX" if you often receive calls to an external handset connected to this machine. 2-6 bizhub 750/600 Before Use 2 2.4 Useful Functions When the Program and Address Book has been registered. Just pressing the [Program] or [Address Book], the information of registration can be called. 2.4.1 Address Book Registering into the [Address Book] the destination to which a message is frequently sent, you can call the information of registration only by pressing the [Address Book] key. Detail [Address Book], [Group] and [Program] can be also registered using the PageScope Web Connection. Using the PageScope Web Connection, setting can be changed or addresses can be registered from a computer connected to the network. Refer to the User's Guide (Network Scanner) for the method to use the PageScope Web Connection. If the Name and Search Character are registered when registering the Address Book for the Address Book, an address can be specified using a reference character.



[You're reading an excerpt. Click here to read official KONICA](http://yourpdfguides.com/dref/588603)

[MINOLTA BIZHUB C352 user guide](http://yourpdfguides.com/dref/588603)

<http://yourpdfguides.com/dref/588603>

Address Book This section describes the procedures for setting the FAX number, E-mail address, Box name, destination name, and retrieval character of an Abbreviated Destination. 1 Press [Utility/Counter] on the control panel to open the Utility Mode screen if it is not already open.

When the optional hard disk has been installed, up to 2000 addresses (0001 to 2000) in total can be registered for the [Address Book] including the [Address Book] set up with the scanner function, etc. can be registered. (If no hard disk has been installed, up to 1000 addresses can be registered.) You can confirm the registered information in the Abbreviation List. 2 Press [One-Touch Registration]. For Utility Mode, the number displayed in the key can also be selected by entering it through the numeric keypad. In the case of [One-Touch Registration], enter 1 through the keypad. bizhub 750/600 2-7 Before Use !

Chapter 2 2 3 Press [Fax]. Before Use Before Use Chapter 2 4 5 Press [Address Book]. Press the destination to register.

The item which can be registered for the Address Book is the following three items. Abbr. Dial: Registering the FAX number. E-Mail: Registering the E-Mail address. This machine can specify an E-Mail address as a fax destination.

If it has been registered. This feature is convenient when transmitting a picture to an E-Mail address simultaneously with fax transmission. User Box:

Registering the Box Name. This machine can specify a box as a fax destination. If it has been registered.

This feature is convenient when storing a picture to a Box simultaneously with fax transmission. If Abbreviated Destination are already registered, you can press [Edit] in that screen to edit the contents of the list. For details, see "Registering the E-Mail for the Address Book" on page 10-7. 6 Press [New]. 2-8 bizhub 750/600 Before Use 2 Press [Name], enter the name of the Abbreviated Destination and press [OK]. 7 For the operation of the entering character, see page 13-3. The name can be a string of up to 24 characters. 8 Enter the destination. When [Abbr. Dial] is selected in the Step 5.

Enter the FAX number to the destination by the keypad. When [E-Mail] is selected in the Step 5. Press [E-Mail Address] and then enter the E-Mail address. When [User Box] is selected in the Step 5. Press [User Box Name] and then select the Box. Numbers containing up to 38 digits can be entered. Unregistered No. is displayed in the [Stored No.] field. To correct a wrong entry, use [Delete] or [C] (clear).

In order to select the box, it is necessary to register the box in advance. For the registration method of the Boxes, see "User's Guide (Box Operations)." 9 Press [Index] to entry the characters for search and then press [OK]. Press the Search key of the Search Character you want to register from among [Main] - [etc]. 10 Press [Line Setting] if necessary to select [Overseas TX], [ECM OFF] or [V.

34 OFF] and then press [OK]. When [E-Mail] or [User Box] is selected in the Step 5. There is no [Line Setting]. 11 Press [OK]. Registration is performed and the registered destination is displayed on a list.

When proceeding with the registration of the Address Book, go to Step 6. bizhub 750/600 2-9 Before Use Chapter 2 2 12 Press [Exit]. Before Use Before Use 2-10 Chapter 2 bizhub 750/600 Before Use 2 2.4.2 Program Registering into the [Program] the destination and communication functions, you can call the information of registration only by pressing the [Program] key. ! Detail Refer to the User's Guide (Network Scanner) for the method to use the PageScope Web Connection. You can register the Scan Setting and Comm. Setting functions. For details, see "Registering the Program" on page 10-22. Program This section describes procedures for registering into the [Program] the registration name and destination.

1 Press [Utility/Counter] on the control panel to open the Utility Mode screen if it is not already displayed. When the optional hard disk has been installed, up to 400 addresses (001 - 400) can be registered for the [Program]. (If no hard disk has been installed, up to 200 addresses can be registered.) 2 Press [One-Touch Registration]. In the Utility Mode, it is also possible to enter a number displayed in the key through the keypad for selection. In the case of [One-Touch Registration], enter the "1" on the keypad. 3 Press [Fax]. bizhub 750/600 2-11 Before Use [Address Book], [Group] and [Program] can be also registered using the PageScope Web Connection. Using the PageScope Web Connection, setting can be changed or addresses can be registered from a computer connected to the network. Chapter 2 2 4 5 Chapter 2 Press [Program].

Before Use Select the Program No. you want to register and then press [Edit]. Before Use 6 Press [Name], enter the name of the Program and press [OK].

The name can be a string of up to 24 characters. For the operation of the entering character, see page 13-3.

7 Press [Destination] to select the destination. When registering a destination that has been already registered, select [Select From Address Book] to enter it through either [Abbr. Dial], [User Box], [Group] or [E-Mail], and then press [OK]. When entering a fax number, press [Direct Input], enter a destination by selecting [Abbr. Dial], [User Box] or [E-Mail] address, and then press [OK].

To correct a wrong entry, use [Delete] or [C] (clear). In order to select a box, it is necessary to register a box in advance. 2-12 bizhub 750/600 Before Use 2 For the registration method of the Boxes, see "User's Guide (Box Operations)." 8 Press [Close] and then press [OK]. To stop registering the Program, press [Cancel]. The list of Program is displayed. When proceeding with the registration of the Program, go to Step 5. 9 Press [Exit]. bizhub 750/600 2-13 Before Use Chapter 2 2 2.5 FAX Screen Before Use Chapter 2 The FAX screen is displayed when the FAX key is pressed on the control panel.

The FAX screen contains [Program], [Group], [Address Book] or [Direct Input]. 1 2 3 4 5 6 7 8 Before Use 15 9 10 11 12 13 14 No. 1 2 3 4 5 Name Job List Program Group Address Book Direct Input Description The list of the jobs in the queue for execution, the job history, and the error jobs is displayed.

Displays Program select screen. Displays Group select screen. Displays Address Book select screen. A screen is displayed in which dialing is made by using a special symbol such as a tone and a pause. Pressing [Scan to E-Mail] allows you to display the keyboard screen in which the E-Mail address is entered.



**You're reading an excerpt. Click here to read official KONICA
MINOLTA BIZHUB C352 user guide**
<http://yourpdfguides.com/dref/588603>

The number of destinations to which transmission has been set is displayed. The remaining amount of memory to be used while in operation is displayed. Press when you want to TX/RX a fax manually. When you press this key, a signal noise sounds. Dest. The display can be switched between the Name and the telephone number of the destination that is being displayed. The page of the list of Program Destination is displayed.

The page of the list of Program Destination can be specified. The menu is displayed in which a method to read an original, such as Original Image Type, Resolution or Application, is set. The menu is displayed in which a method for communication such as Timer TX or Polling RX is set. 6 7 8 9 No. of Dest. Memory Off-Hook Name 10 11 12 Page Indicator Page List Scan Setting 13 Comm. Setting 2-14 bizhub 750/600 Before Use 2 Name Destination Indicator Sub Area Description The destination set is displayed. The description according to the operations being set on the right side is displayed. For the operation of the fax, the explanation of each function and the Broadcast Destinations are displayed. No. 14 15 bizhub 750/600 2-15 Before Use Chapter 2 2.2.6 User Authentication and Account Track Before Use Chapter 2 When using this machine, the machine may be set so that the User name, the Department name and the Password are to be entered. Entering the necessary information in the screen displayed shows the normal screen. For particulars of the department name and the user name, contact your administrator. 2.

6.1 When the User Authentication has been set Before Use ! Detail For details of the User Authentication and the Account Track, see "User's Guide" (Copy Operations). 2.6.2 When the Account Track has been set 2-16 bizhub 750/600 Before Use 2 2.7 Fax reception using the Box Using the PC-FAX RX feature and the Memory RX functions of this machine allows you to save the documents received in the box without printing them immediately. And when a confidential document is received, it is saved automatically in the Confidential User Box. Documents saved in the box can be printed with this machine or imported into the computer on the network. In this section, a general description is given of the fax reception by means of the box. Detail For the creation of a box and the download of documents received in the box through the PC-FAX RX feature, see "User's Guide (Box Operations).

When the box of this machine is specified as a Destination while in the fax sending, documents that have been read can be saved in the box. bizhub 750/600 2-17 Before Use ! Chapter 2 2.2.7.1 Type of boxes (With hard disk installed) Before Use When the optional hard disk has been installed, both the Public User Box/ Personal User Box and System Box can be used. - For the Public User Box, there is a Specified Box (No.

1 to 999999999) provided. - For the System User Box, there are 4 types of boxes available, such as Bulletin Board User Box / Polling TX User Box / Memory RX User Box / Secure Print User Box. For this machine, using these boxes allows the functions listed in the table below to be used. Box Name Public User Box/Personal User Box Specified Box (Box: No. 1 - 999999999) Function The Public/Personal User Box functions as the Confidential User Box when the Confidential RX is set to ON.

When the specified box is specified as a place into which documents received are stored in the PCFAX RX feature, and when the TSI User Box Setting is specified, the documents received are saved in the box with a relevant number. In the case of the PC-FAX RX feature: Saved in the box with a number specified in the subaddress by the sender. In the case of the TSI RX: Saved in the box a number corresponding to the TSI User Box Setting. Before Use Chapter 2 ! Detail For details, see "Operations of the PCFAX RX feature" (p. 2-21). 2-18 bizhub 750/600 Before Use 2 Function Bulletin Board User Box This is a box into which documents for perusal are registered. Documents registered in the bulletin board user box can be polling transmitted according to the polling instruction from the other party. Box Name System User Box ! Detail For details, see "Bulletin" (p. 9-8). Polling TX User Box Originals read for the polling transmission are saved in this box.

! Detail For details, see "Polled Transmission" (p. 9-2). Memory RX User Box (Box: No.0) When the Memory RX is set to ON, documents received are not printed but saved in this box. ! Detail For details, see "Memory Reception" (p. 8-5). When the fixed box is specified as a place into which documents received are stored in the PCFAX RX feature, the documents received are saved in this box. ! Detail For details, see "Operations of the PCFAX RX feature" (p. 2-21).

Secure Print User Box This box is used when the Secure print is made optionally in the Print controller.

! Detail For details of the Secure Print User Box, see "User's Guide (Printer Operations)". bizhub 750/600 2-19 Before Use Chapter 2 2.2.7.2 Type of boxes (with no hard disk installed) Before Use When no hard disk has been installed, following boxes can be used. Chapter 2 Box Name System User Box Bulletin Board User Box Function This is a box into which documents for perusal are registered.

Documents registered in the bulletin board user box can be polling transmitted according to the polling instruction from the other party. Before Use ! Detail For details, see "Bulletin" (p. 9-8). Polling TX User Box Originals read for the polling transmission are saved in this box. ! Detail For details, see "Polled Transmission" (p.

9-2). Memory RX User Box When the Memory RX is set to ON, documents received are not printed but saved in this box. ! Detail For details, see "Memory Reception" (p. 8-5). Confidential User Box Confidential document is saved in this box without being printed. ! Detail For details, see "Utilize a document received as Confidential Reception" (p. 82). 2-20 bizhub 750/600 Before Use 2 2.7.3 Operations of the PC-FAX RX feature ! For details, see "PC-Fax RX Setting" (p.

11-43). When setting the PC-FAX RX feature or TSI User Box Setting, documents received are saved in the Fixed Box (0) or Public User Box (1 to 999999999) in the optional hard disk. The box into which documents received are saved is set in [PC-Fax RX Setting] of the Utility Mode. For the relationship between [PC-Fax RX Setting] and the reception method, see the table below. [PC-Fax RX Setting] of the Utility Mode PC-Fax RX Setting: OFF Reception method Documents received are not saved in the box, but printed immediately. In the following cases, however, documents received are saved in the box. 1. In the case of the Confidential RX (When the sub-address in the F-code is representing a number for the Confidential User Box): Documents confidentially received are saved in the Confidential User Box regardless of the setting of the PC-FAX RX feature.



[You're reading an excerpt. Click here to read official KONICA MINOLTA BIZHUB C352 user guide](http://yourpdfguides.com/dref/588603)
<http://yourpdfguides.com/dref/588603>

When the sub-address is different from a number for the Confidential User Box, a communication error results. 2. When TSI User Box Setting is set to ON: Documents received are stored in the box set by TSI User Box Setting. 3. When the Memory RX is set to ON: When not corresponding to 1. or 2. above, documents received are saved in the Memory RX User Box.

Documents received are saved in the Memory RX User Box. In the following cases, however, documents received are saved in a different box. 1. In the case of the Confidential RX (When the sub-address in the F-code is representing a number for the Confidential User Box): Documents received are saved in the Confidential User Box regardless of the setting of the PC-FAX RX feature. When the subaddress is different from a number for the Confidential User Box, a communication error results.

PC-Fax RX Setting: ON RX Output: Fixed Box bizhub 750/600 2-21 Before Use Chapter 2 Detail 2 [PC-Fax RX Setting] of the Utility Mode PC-Fax RX Setting: ON RX Output: Specified Box Reception method Before Use Before Use Documents received are saved in the Specified Box (1 to 999999999) with a number specified by the sub-address. In the following cases, however, documents received are saved in a different box. 1. When the sub-address is not specified: Documents received are saved in the Memory RX User Box. 2. When there is no appropriate Specified Box: Follow the setting in [Incorrect User Box No. Entry] of Utility Mode. 3. In the case of the Confidential RX (When the sub-address of the F-code is representing a number for the confidential user box): Documents received are saved in the Confidential User Box regardless of the setting of the PC-FAX RX feature. When the subaddress is different from a number for the Confidential User Box, follow the setting in [Incorrect User Box No. Entry] of Utility Mode. Chapter 2 2-22 bizhub 750/600 Transmission 3 Transmission Chapter 3 3 3.1 Transmission Transmission Simple FAX Transmission Simple FAX Transmission The following is an explanation of procedures for simple FAX transmission. Chapter 3 Although the explanation here covers the procedure for sending a one-sided document using the basic procedure, various functions are available for each step of the procedure to make sending facsimiles even more convenient. Refer "Transmission Applications" on page 7-2 to for further details. Transmission 1 2 Press [Fax] on the control panel to open the FAX screen. Press [Scan Setting] to set the function and then press [OK]. The Scan Setting in the FAX screen is set as follows at the time of purchase. Original Image Type Text Density Standard Simplex/Duplex Single sided Resolution Fine For details, see "Setting Transmission Conditions" on page 3-10. 3-2 bizhub 750/600 Transmission 3 For details, see "Opening the Scan Setting Screen and Comm. Setting screen" on page 7-2. 3 Press [Comm. Setting] to set the function and then press [OK]. See "Transmission Applications" on page 7-2 for detail. 4 Select the destination.

Setting the destination is as follows. Keypad Program Group Address Book Direct Input Registering the Fax number of the destination in advance with Abbreviated Destination or Program makes it simple to select the destination. When canceling a destination that has been selected, select a destination you want to cancel once again. Press [RESET] to clear the whole entry. For details, see "Registering the Address Book" on page 10-3 and "Registering the Program" on page 10-22.

When [Manual Destination Input] in [Security Setting] of the Utility Mode is set to [Restrict], [Direct Input] is not displayed. For the setting of [Manual Destination Input], contact your Administrator. The fax number entered is displayed in the Broadcast Destinations. bizhub 750/600 3-3 Transmission Chapter 3 3 5 Place the original on the machine. For details, see "Placing the Original on the Machine" on page 3-5. Transmission Transmission Chapter 3 6 Press [Start]. The machine begins to scan the original and transmission starts. The following screen will appear if the TX Result Report Check screen is programmed to appear. If you want to print the TX Report, press [Yes]. To interrupt transmission, press [STOP].

When it can not transmit, see page 5-2. If the transmission fails, TX Report is automatically output (if the TX Report is programmed to print). For details of Report Settings, see "Report Settings" on page 11-52. For more information about the TX Report, see "TX Report" on page 12-7. 3-4 bizhub 750/600 Transmission 3 3.2 Placing the Original on the Machine The ADF and platen glass can be used to scan originals with this machine. When an original is placed in the ADF, the original is automatically fed through the ADF and scanned. 3.2.1 Using the ADF When using the ADF, multiple originals can be scanned automatically.

In addition, two-sided originals can be sent. Using the ADF 1 2 3 Close the ADF. Align the originals starting with the first page. Place the originals in the ADF with the side to be scanned facing up. To make a proper print of the Header Information (Sender Name/ Sender Fax No.), insert the front edge of the original into the ADF. 4 Adjust paper guides. In Mixed Original mode, extend the paper guides to fit the largest paper size, and place the remaining originals aligned in the top left corner. bizhub 750/600 3-5 Transmission Chapter 3 3 3.2.

2 Placing Originals on the Platen Glass Transmission Use the platen glass for originals that cannot be placed in the ADF (such as a book or thick/thin originals). Placing Originals on the Platen Glass 1 2 Chapter 3 Open the ADF. Place the original FACE DOWN in the left rear corner, aligning the edge with the left measuring guide. Transmission 3 3.2.3 Gently close the ADF. Sending Multiple Originals from the Platen Glass Originals that cannot be sent with the ADF can be sent by using the platen glass. Sending Multiple Originals from the Platen Glass 1 2 3 If the FAX screen is not displayed, press [Fax] on the control panel to open the FAX screen. Select a destination. Set the desired functions as necessary.

3-6 bizhub 750/600 Transmission 3 Place the original on the platen glass. Press [Scan Setting] - [Separate Scan] - [OK] and then press [Start]. 4 5 Place the next original on the platen glass and press [Start]. Repeat this procedure until all originals to be sent have been scanned. The scanned originals are stored in memory. 6 7 Press [Finish]. The Document reading mode is canceled. Press [Start]. Transmission begins. Box Access GHI Fax Scan Copy Reset ABC DEF Interrupt Power JKL MNO Mode Memor Memory Utility/ Counter Mode Chec Check PQRS TUV WXYZ Proof Copy Stop Start Star Data Main Power P er bizhub 750/600 3-7 Transmission Chapter 3 3 3.



[You're reading an excerpt. Click here to read official KONICA MINOLTA BIZHUB C352 user guide](http://yourpdfguides.com/dref/588603)
<http://yourpdfguides.com/dref/588603>

2.4 Transmission Transmitting Originals by Using both the ADF and the Platen Glass You can scan originals by using both the ADF and the platen glass and you can also scan the large amounts of originals by placing them on the ADF in several times. Transmitting Originals by Using both the ADF and the Platen Glass Chapter 3 1 2 3 4 If the FAX screen is not displayed, press [Fax] on the control panel to open the FAX screen. Select a destination. Set the desired functions as necessary.

Place the original on the platen glass. Press [Scan Setting] - [Separate Scan] - [OK] and then press [Start]. Document placed on the ADF will take precedence over those on the platen glass. For details, see "Placing the Original on the Machine" on page 3-5. Transmission 5 Place the next original on the ADF or the platen glass and press [Start].

Repeat this procedure until all originals to be sent have been scanned. The scanned originals are stored in memory. 6 Press [Finish]. The Document reading mode is canceled. 3-8 bizhub 750/600 Transmission 3 Press [Start]. Transmission begins. Box Access GHI 7 Fax Scan Copy Reset ABC DEF Interrupt Power JKL MNO Mode Memor Memory Utility/ Counter Mode Chec Check PQRS TUV WXYZ Proof Copy Stop Start Star Data Main Power P er bizhub 750/600 3-9 Transmission Chapter 3 3 3.3 Setting Transmission Conditions Transmission Original Image Type, Density, Simplex/Duplex and Resolution are displayed when [Scan Setting] is pressed on the FAX screen. These can be used to set transmission conditions according to the type of original to be sent. ! Detail The condition for transmission cannot be set in units of page.

Chapter 3 Setting Transmission Conditions 1 2 Press [Scan Setting] on the FAX screen. Press the key desired to be set. Transmission 3-10 bizhub 750/600 Transmission 3 3.3.1 Original Image Type Set Quality according to the contents of the original. There are 4 types of Quality settings. Text is default at the time of purchase. Text/Photo Press this when scanning originals containing both text and photographs (half-tone). Select this mode in either case when both characters and pictures are contained in one page, and when both pages of characters and those of pictures are contained in one document. Press this when scanning originals containing photographs (Halftone) only.

Press this when scanning originals containing text which are thinly written in pencil as a whole. Photo Dot Matrix 3.3.2 Density Set Density according to the lightness or darkness of the original. Density can be set in 9 steps.

[Std.] is set at the time of purchase. Light Std.(Auto) Press to scan originals so that they are lighter than the density detected with Standard. Press to scan originals at a density that is between Darker and Lighter.

Used when returning to the default setting. bizhub 750/600 3-11 Transmission Text Press this when scanning originals containing text only. If this mode is selected and an original of pictures is scanned, neutral tints of the pictures turn black without being reproduced. Chapter 3 3 Dark Transmission Press to scan originals so that they are darker than the density detected with Standard. 3.3.3 Simplex/Duplex This is used to set the manner in which originals are scanned according to the type of original. There are 2 types. Single sided is set at the time of purchase. Transmission Chapter 3 Single sided Double sided Press this when scanning one-sided originals.

Press this when scanning two-sided originals. 3.3.4 Resolution This is used to set the fineness at which originals are to be scanned. The following 4 settings are available for Resolution. Fine is set at the time of purchase. Std. Fine Super Fine Ultra Fine Press this when the sending time is cut short. Press this when scanning normal originals. Press this when scanning originals containing small graphics or text.

Press this when scanning originals containing especially fine graphics or text. 3-12 bizhub 750/600 Transmission 3 ! Detail As originals are scanned with increasing fineness, the amount of data that is sent also increases, and more time is required for transmission. When Ultra Fine or Super Fine has been selected and the receiving machine is not equipped with the resolution, originals are sent at a resolution corresponding to the reception capability of the receiving machine. bizhub 750/600 3-13 Transmission Chapter 3 3 3.3.

5 Transmission Confirming Settings and Communication Results The settings and communication results of the FAX screen and FAX Application screen can be confirmed by using [Mode Check] on the control panel. Confirming Settings and Communication Results 1 2 Chapter 3 Press [Fax] on the control panel. Press [Mode Check] on the control panel. Press a key of setting you want to confirm. 3 Transmission 4 Confirm the settings.

The four kinds of the setting as follows can be confirmed. Destination Confirming the destination. Pressing [Dest.] in the screen shown by pressing [Details] allows you to change the destination. 3-14 bizhub 750/600 Transmission 3 Scan Setting Confirming the Scan Setting. Press each setting key in the screen, and the Scan Setting screen corresponding to each appears, and the setting can be change. For details of the Scan Setting screen, see "Opening the Scan Setting Screen and Comm. Setting screen" on page 7-2. Pressing [Fwd.] to display the next screen, pressing [Back] to display the previous screen.

Communication Setting Confirming the Communication Setting. Press each setting key in the screen, and The Communication Setting or Line Setting screen corresponding to each appears., and the setting can be change. For details of the Communication Setting screen, see "Opening the Scan Setting Screen and Comm. Setting screen" on page 7-2. Pressing [Fwd.] to display the next screen, pressing [Back] to display the previous screen. bizhub 750/600 3-15

Transmission Chapter 3 3 Transmission E-Mail Setting When transmitting by the E-Mail, you can confirm or input the File Name, Subject, From (the Sender's E-Mail address), and Text. Chapter 3 Transmission When no setting is made in [From], an E-Mail address that has been set in [Administrator Registration] in the Utility Mode is put in it. For details of [Administrator Registration], see "User's Guide (Copy Operations).

" For details of the Default of the Subject and Text, see page 10-34, page 10-40. 5 Press [Close] twice after completion of confirmation. The FAX screen will be restored. ! Detail When the Scan Setting or Communication Setting is changed, It moves to the Scan Setting screen or Communication Setting screen.



[You're reading an excerpt. Click here to read official KONICA MINOLTA BIZHUB C352 user guide](http://yourpdfguides.com/dref/588603)
<http://yourpdfguides.com/dref/588603>