



# Your PDF Guides

You can read the recommendations in the user guide, the technical guide or the installation guide for BRIGGS & STRATTON 110600. You'll find the answers to all your questions on the BRIGGS & STRATTON 110600 in the user manual (information, specifications, safety advice, size, accessories, etc.). Detailed instructions for use are in the User's Guide.

**User manual BRIGGS & STRATTON 110600**  
**User guide BRIGGS & STRATTON 110600**  
**Operating instructions BRIGGS & STRATTON 110600**  
**Instructions for use BRIGGS & STRATTON 110600**  
**Instruction manual BRIGGS & STRATTON 110600**



- Ⓒ(GB) *Operating & Maintenance Instructions*
- Ⓒ(D) *Betriebsanleitung & Wartungsvorschriften*
- Ⓒ(DK) *Drifts- og vedligeholdelsesvejledning*
- Ⓒ(E) *Instrucciones de Mantenimiento & Operación*
- Ⓒ(F) *Instructions d'utilisation et de maintenance*
- Ⓒ(GR) *Οδηγίες Λειτουργίας & Συντήρησης*
- Ⓒ(I) *Istruzioni per l'uso e la manutenzione*
- Ⓒ(N) *Anvisninger for bruk og vedlikehold*
- Ⓒ(NL) *Gebruiksaanwijzing*
- Ⓒ(P) *Instruções de operação e de manutenção*
- Ⓒ(S) *Instruktionsbok*
- Ⓒ(SF) *Käyttö & Huolto-ohjeet*

Model	120000	Intek	825/850/875 Series
		Intek Edge	825/850 Series
		Intek Pro	825 Series

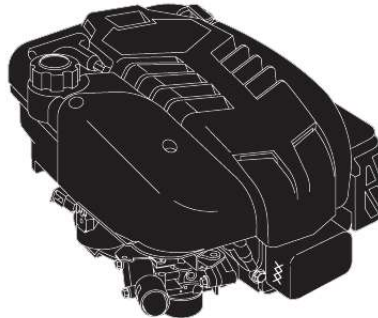

BRIGGSandSTRATTON.com

© Copyright Briggs & Stratton Corporation  
Milwaukee, Wisconsin 53201 U.S.A.

Form No. MS-3783-3/07  
Printed in U.S.A.



[You're reading an excerpt. Click here to read official BRIGGS & STRATTON 110600 user guide](http://yourpdfguides.com/dref/3638578)  
<http://yourpdfguides.com/dref/3638578>

**Manual abstract:**

S.A. Fig. 1 7 8 9 1 10 6 12 11 5 4 3 2 Fig. @@3 Fig. 4 Fig. 5 Fig. @@@@1 2 3 4 5 6 7 8 9 10 11 12 1 Engine Model Type xxxxxx xxxx xx Resistor spark plug Carburetor Primer bulb, if equipped Choke lever, if equipped Air cleaner Fuel fill Rope handle Finger guard Oil fill/Dipstick Muffler guard Code TUNE-UP SPECIFICATIONS Armature air gap . . .

. . . . .  
. . . . .  
0.25 - 0.36 mm . . . . .

. . . . .  
. . . . .  
. . (0.010 - 0.014 in.  
) Spark plug gap . . . . .

. . 0.51 mm (0.20 in.) Valve clearance with valve springs installed and piston 6 mm past top dead center (check when engine is cold). See Repair Manual P/N 272147. Intake valve clearance . . .

. . . . .  
. . 0.10 - 0.20 mm . .

. . . . .  
. . . (0.004 - 0.  
008 in.) Exhaust valve clearance . . . .  
. . . 0.10 - 0.20 mm . . . . .

(0.004 - 0.008 in.) Note: Engine power will decrease 3-1/2% for each 1,000 feet (300 meters) above sea level and 1% for each 10 F (5.6 C) above 77 F (25 C). It will operate satisfactorily at an angle up to 15 . Refer to the equipment operator manual for safe allowable operating limits on slopes. Hazard Symbols and Meanings xxxxxxxx Fire Explosion Shock Kickback Toxic Fumes Hot Surface Hazardous Chemical Moving Parts International Symbols and Meanings Muffler/spark arrester, if equipped Record your engine Model, Type and Code numbers here for future use. SAFETY SPECIFICATIONS BEFORE OPERATING ENGINE Read entire Operating & Maintenance Instructions AND the instructions for the equipment this engine powers.\* Failure to follow instructions could result in serious injury or death.

\* Briggs & Stratton does not necessarily know what equipment this engine will power. For that reason, you should carefully read and understand the operating instructions for the equipment on which your engine is placed. Safety Alert Choke Read Operator's Manual Record your date of purchase here for future use. TECHNICAL INFORMATION Engine Power Rating Information The gross power rating for individual gas engine models is labeled in accordance with SAE (Society of Automotive Engineers) code J1940 (Small Engine Power & Torque Rating Procedure), and rating performance has been obtained and corrected in accordance with SAE J1995 (Revision 2002-05). Torque values are derived at 3060 RPM; horsepower values are derived at 3600 RPM. Actual gross engine power will be lower and is affected by, among other things, ambient operating conditions and engine-to-engine variability. Given both the wide array of products on which engines are placed and the variety of environmental issues applicable to operating the equipment, the gas engine will not develop the rated gross power when used in a given piece of power equipment (actual on-site" or net power). This difference is due to a variety of factors including, but not limited to, accessories (air cleaner, exhaust, charging, cooling, carburetor, fuel pump, etc.), application limitations, ambient operating conditions (temperature, humidity, altitude), and engine-to-engine variability. Due to manufacturing and capacity limitations, Briggs & Stratton may substitute an engine of higher rated power for this Series engine.

Oil Fuel Fuel Shutoff On Off Stop Make you aware of hazards associated with engines Inform you of the risk of injury associated with those hazards, and Tell you how to avoid or reduce the risk of injury. A signal word (DANGER, WARNING, or CAUTION) is used with the alert symbol to indicate the likelihood and the potential severity of injury. In addition, a hazard symbol may be used to represent the type of hazard. DANGER indicates a hazard which, if not avoided, will result in death or serious injury. WARNING indicates a hazard which, if not avoided, could result in death or serious injury.

CAUTION indicates a hazard which, if not avoided, might result in minor or moderate injury. CAUTION, when used without the alert symbol, indicates a situation that could result in damage to the engine. THE OPERATING & MAINTENANCE INSTRUCTIONS CONTAIN SAFETY INFORMATION TO:  
DANGER Contents are HARMFUL OR FATAL IF SWALLOWED. Avoid contact to eyes, skin, or clothing. Do not take internally.

Avoid breathing the mist or vapor. Overexposure to eyes or skin can cause irritation. Keep stabilizer out of the reach of children. Fuel stabilizer is a hazardous chemical.\*\* GENERAL INFORMATION In the state of California, OHV Model 120000 engines are certified by the California Air Resources Board to meet emissions standards for 125 hours. Such certification does not grant the purchaser, owner or operator of this engine any additional warranties with respect to the performance or operational life of this engine. This engine is warranted solely according to the product and emissions warranties stated elsewhere in this manual. Fresh Start™ fuel cap is designed to hold a cartridge which contains fuel stabilizer. IF SWALLOWED, call physician immediately.

Do not induce vomiting.

If inhaled, remove to fresh air. In case of eye or skin contact, flush with water for 15 minutes. Store unopened cartridges in a cool, dry, well-ventilated area. Keep open cartridge in fuel cap, and fuel cap closed on fuel tank when not in use. \*\* Fuel stabilizer contains 2,6-di-tert-butylphenol (128-39-2) and aliphatic petroleum distillate (64742-47-8). Model 120000 Bore . . . . .

. . . . .  
. . . . .  
. . . . . 68.26 mm (2.69 in.) Stroke . .

.....  
.....  
. 52.00 mm (2.05 in.) Displacement .  
.....

. 190 cc (11.58 cu. in.) **WARNING** The engine exhaust from this product contains chemicals known to the State of California to cause cancer, birth defects, or other reproductive harm. **1 WARNING** Gasoline and its vapors are extremely flammable and explosive. Fire or explosion can cause severe burns or death. **WHEN ADDING FUEL** Turn engine **OFF** and let engine cool at least 2 minutes before removing gas cap. Fill fuel tank outdoors or in well-ventilated area.

Do not overfill fuel tank.

Fill tank to approximately 1-1/2 inches below top of neck to allow for fuel expansion. Keep gasoline away from sparks, open flames, pilot lights, heat, and other ignition sources. Check fuel lines, tank, cap, and fittings frequently for cracks or leaks. Replace if necessary. **WHEN STARTING ENGINE** Make sure spark plug, muffler, fuel cap and air cleaner are in place.

Do not crank engine with spark plug removed. If fuel spills, wait until it evaporates before starting engine. If engine floods, set choke to **OPEN/RUN** position, place throttle in **FAST** and crank until engine starts. **WHEN OPERATING EQUIPMENT** Do not tip engine or equipment at angle which causes gasoline to spill. Do not choke carburetor to stop engine.

**WHEN TRANSPORTING EQUIPMENT** Transport with fuel tank **EMPTY** or with fuel shut-off valve **OFF**. **WHEN STORING GASOLINE OR EQUIPMENT WITH FUEL IN TANK** Store away from furnaces, stoves, water heaters or other appliances that have pilot light or other ignition source because they can ignite gasoline vapors.



[You're reading an excerpt. Click here to read official BRIGGS & STRATTON 110600 user guide](http://yourpdfguides.com/dref/3638578)  
<http://yourpdfguides.com/dref/3638578>

**WARNING** Engines give off carbon monoxide, an odorless, colorless, poison gas. Breathing carbon monoxide can cause nausea, fainting or death. Start and run engine outdoors. Do not start or run engine in enclosed area, even if doors or windows are open. **OIL RECOMMENDATIONS CAUTION:** Engine shipped from Briggs & Stratton without oil. Before starting engine, fill with oil. Do not over-fill. Use a high quality detergent oil classified For Service SF, SG, SH, SJ" or higher such as Briggs & Stratton 30, Part Number 100005.

Use no special additives with recommended oils. Do not mix oil with gasoline. **WARNING** Running engines produce heat. Engine parts, especially muffler, become extremely hot. Severe thermal burns can occur on contact. Combustible debris, such as leaves, grass, brush, etc. can catch fire. Allow muffler, engine cylinder and fins to cool before touching. Remove accumulated combustibles from muffler area and cylinder area. Install and maintain in working order a spark arrester before using equipment on forest-covered, grass-covered, brush-covered unimproved land.

The state of California requires this (Section 4442 of the California Public Resources Code). Other states may have similar laws. Federal laws apply on federal land. Fig. 2 Choose the SAE viscosity grade of oil from this chart that matches the starting temperature anticipated before the next oil change. \* Air cooled engines run hotter than automotive engines. The use of non-synthetic multi-viscosity oils (5W-30, 10W-30, etc.) in temperatures above 40 F (4 C) will result in higher than normal oil consumption. When using a multi-viscosity oil, check oil level more frequently. \*\* Use of SAE 30 oil below 40 F (4 C) will result in hard starting and possible engine damage due to inadequate lubrication.

Note: Synthetic oil meeting ILSAC GF-2, API certification mark and API service symbol (shown at left) with SJ/CF ENERGY CONSERVING" or higher, is an acceptable oil at all temperatures. Use of synthetic oil does not alter required oil change intervals. Check oil level. Oil capacity is about (22 ounces or .65 liter) if engine is not equipped with oil filter. If engine is equipped with oil filter, add 4 more ounces (.1 liter) when changing oil filter. Place engine level and clean around oil fill. Remove dipstick, wipe with clean cloth, insert and tighten down again. Remove dipstick and check oil level.

Oil should be at FULL mark. If oil is required, add slowly. Tighten dipstick firmly before starting engine. **WARNING** Rotating parts can contact or entangle hands, feet, hair, clothing, or accessories. Traumatic amputation or severe laceration can result. Operate equipment with guards in place. Keep hands and feet away from rotating parts. Tie up long hair and remove jewelry. Do not wear loose-fitting clothing, dangling drawstrings or items that could become caught. **FUEL RECOMMENDATIONS** Use clean, fresh, lead-free, regular gasoline with a minimum of 85 octane.

Leaded gasoline may be used if it is commercially available and if unleaded is unavailable. Purchase fuel in quantity that can be used within 30 days. See storage instructions. In U.S.

A. leaded gasoline may not be used. Some fuels, called oxygenated or reformulated gasolines, are gasolines blended with alcohols or ethers. Excessive amounts of these blends can damage the fuel system or cause performance problems. If any undesirable operating symptoms occur, use gasoline with a lower percentage of alcohol or ether.

This engine is certified to operate on gasoline. Exhaust Emission Control System: EM (Engine Modifications). Do not use gasoline which contains Methanol. Do not mix oil with gasoline. For engine protection, we recommend using Briggs & Stratton Fuel Stabilizer available from an Authorized Briggs & Stratton Service Dealer. **WARNING** Starting engine creates sparking. Sparking can ignite nearby flammable gases. Explosion and fire could result. If there is natural or LP gas leakage in area, do not start engine. Do not use pressurized starting fluids because vapors are flammable.

**WARNING** Unintentional sparking can result in fire or electric shock. Unintentional start-up can result in entanglement, traumatic amputation, or laceration. **BEFORE REPAIRS PERFORMING ADJUSTMENTS OR WARNING** Rapid retraction of starter cord (kickback) will pull hand and arm toward engine faster than you can letgals. If this engine was originally equipped with resistor spark plug, use same type of spark plug for replacement. \*\*\* On string trimmer applications: clean debris at each refueling, sooner if needed; have qualified technician clean air cooling system every 30 hours, every season, sooner if needed especially in high debris conditions. **WARNING OIL FILTER** Change oil filter, if equipped Replace oil filter after every 100 hours of operation. 1.

Drain engine oil. 2. Before installing new filter, lightly oil filter gasket with fresh, clean oil.

3. Screw filter on by hand until gasket contacts oil filter adapter. Tighten 1/2 to 3/4 turn more. 4. Refill engine with fresh oil.

5. Start and run engine at idle to check for leaks. Stop engine. 6. Re-check oil level.

Add oil if required. Fig. 8 **AIR CLEANER STARTING/STOPPING WARNING** All engines have an air cleaner cartridge. The cartridge is either flat or oval (see illustrations). In addition, some engines have a pre-cleaner. **CAUTION:** Do not use pressurized air or solvents to clean cartridge. Pressurized air can damage cartridge; solvents will dissolve cartridge. **PRE-CLEANER** To clean pre-cleaner (if equipped), separate it from cartridge and wash in liquid detergent and water. Air dry thoroughly. Do not oil pre-cleaner.

Re-assemble dry pre-cleaner on clean cartridge. **OVAL AIR CLEANER** 1. Loosen screws and lift cover. 2. Carefully remove pre-cleaner (if equipped) and cartridge assembly. 3. After servicing pre-cleaner and cartridge, assemble pre-cleaner on cartridge. 4. Install cartridge/pre-cleaner assembly in base. 5. Place cover on air cleaner and tighten screws securely to base. **SQUARE AIR CLEANER** 1. Loosen screw and tilt cover down. Carefully remove pre-cleaner (if equipped) and cartridge assembly from cover 2. After servicing pre-cleaner and cartridge, place pre-cleaner, if equipped, over cartridge pleats with arrows in direction shown (pre-cleaner lip will be at bottom of pleats).

3. Install pre-cleaner and cartridge assembly in cover. 4. Insert tabs on cover into slots in bottom of base. 5.

Tilt cover up and tighten screw securely to base. Fig. 4 **BEFORE STARTING** Check oil level. Add fuel and re-install fuel cap. Move throttle control to FAST position. Push primer bulb 3 times, if equipped. Move choke lever to close. Fig. 5 **STARTING ENGINE** Pull back safety brake control handle then, Pull rope handle slowly until resistance is felt. Then pull cord rapidly to overcome compression, prevent kickback and start engine.

OR, Turn key to start. **CAUTION:** To prolong starter life, use short starting cycles (5 seconds maximum, then wait one minute).



[You're reading an excerpt. Click here to read official BRIGGS & STRATTON 110600 user guide](http://yourpdfguides.com/dref/3638578)  
<http://yourpdfguides.com/dref/3638578>

Follow equipment manufacturer's recommendations for charging battery. Allow engine to warm up. If choke equipped: Slowly adjust toward RUN position. Wait until engine runs smoothly before each choke adjustment. Fig. 6 STOPPING Do not stop engine by moving choke control to CHOKE. Backfire, fire or engine damage could occur. 3 WARNING FUEL SYSTEM WARNING Replacement parts for fuel system (tank, hoses, valves, etc.

) must be the same quality as original parts, otherwise fire can occur. STORAGE Engines stored over 30 days need special attention. To prevent gum from forming in fuel system or on essential carburetor parts: a) if fuel tank contains oxygenated or reformulated gasoline (gasoline blended with an alcohol or an ether), run engine until it stops from lack of fuel, or b) if fuel tank contains gasoline, either run engine until it stops from lack of fuel, or add a gasoline stabilizer to the gas in the tank. SERVICE We recommend that you see an authorized Briggs & Stratton Service Dealer for all maintenance and service of the outboard and outboard parts. Use only genuine Briggs & Stratton parts.

Each Authorized Briggs & Stratton Service Dealer carries a stock of Genuine Briggs & Stratton Parts and is equipped with special service tools. Trained mechanics assure expert repair service on all Briggs & Stratton engines. Only dealers recognized as Authorized Briggs & Stratton" meet the higher Briggs & Stratton service standards. You may locate your nearest Authorized Briggs & Stratton Service Dealer in our dealer locator map on our web site Yellow TM PagesTM" directory under Lawn Mowers" or Engines, Gasoline" or Gasoline Engines," or similar category. Note: Walking fingers logo and Yellow Pages" are registered trademarks in various jurisdictions.

www.briggspowerproducts.com or in the Replacing Fuel Filter Remove the engine cover. Replace fuel filter. Check filter for water or debris. If found, clean fuel system. Reinstall the engine cover. Fig. 9 SPARK PLUG WARNING DO NOT check for spark with spark plug removed. Use only Briggs & Stratton Spark Tester , to check for spark.

@@If the spark plug is worn or dirty the engine will be hard to start. @@Then engine and fuel can be stored. 1. Change oil. 2. @@Replace spark plug and crank slowly to distribute oil. 3. Clean engine of debris. 4. @@Part Oil (20 oz.

).....

.....

.....

..... 100005 Oil (48 oz.

).....

.....

.....

..... 100028 Oil filter .

.....

.....

.....

.....

692513 Oil pump kit (uses standard electric drill).....

.....

@@..... 5058 Fuel stabilizer (4.2 oz., 125 ml bottle).....

..... 5041 Fuel filter.....

.....

.....

.....

.. 298090 (5018) Flat air cleaner cartridge.....

.....

. 491588 (5043) Flat air cleaner pre-cleaner.....

.....

.... 493537 Oval air cleaner cartridge.....

.....

.....

... 498596 Oval air cleaner pre-cleaner.....

.....

273356 Resistor spark plug.....

.....

.....

... 499608 Long life platinum spark plug.....

.....

.....

5066 (OHV engines - set gap to .020 in. or .50 mm) Spark tester.....

.....

.....

.....

.. 19368 Spark plug wrench.....

.....  
.....

.. @@Consult the repair manual, Part No. @@@@Inspect and clean before every use. @@Replace if damaged. Periodically remove grass and chaff build-up from engine. @@Water could contaminate fuel system. @@@@EPA. @@@@If any covered part on your engine is defective, the part will be repaired or replaced by B&S. Owner's Warranty Responsibilities As the small off-road engine owner, you are responsible for the performance of the required maintenance listed in your Operating and Maintenance Instructions. B&S recommends that you retain all your receipts covering maintenance on your small off-road engine, but B&S cannot deny warranty solely for the lack of receipts or for your failure to ensure the performance of all scheduled maintenance. As the small off-road engine owner, you should however be aware that B&S may deny you warranty coverage if your small off-road engine or a part has failed due to abuse, neglect, improper maintenance or unapproved modifications. You are responsible for presenting your small off-road engine to an Authorized B&S Service Dealer as soon as a problem exists. The undisputed warranty repairs should be completed in a reasonable amount of time, not to exceed 30 days. If you have any questions regarding your warranty rights and responsibilities, you should contact a B&S Service Representative at 1-414-259-5262.

The emissions warranty is a defects warranty. Defects are judged on normal engine performance. The warranty is not related to an in-use emissions test. Briggs & Stratton Emissions Control Defects Warranty Provisions The following are specific provisions relative to your Emissions Control Defects Warranty Coverage. It is in addition to the B&S engine warranty for non-regulated engines found in the Operating and Maintenance Instructions. 1. Warranted Parts Coverage under this warranty extends only to the parts listed below (the emissions control systems parts) to the extent these parts were present on the engine purchased. a. Fuel Metering System Cold start enrichment system (soft choke) Carburetor and internal parts Fuel pump Fuel line, fuel line fittings, clamps Fuel tank, cap and tether Carbon canister b. Air Induction System Air cleaner Intake manifold Purge and vent line c. Ignition System Spark plug(s) Magneto ignition system d. Catalyst System Catalytic converter Exhaust manifold Air injection system or pulse valve e. Miscellaneous Items Used in Above Systems Vacuum, temperature, position, time sensitive valves and switches Connectors and assemblies 2. Length of Coverage B&S warrants to the initial owner and each subsequent purchaser that the Warranted Parts shall be free from defects in materials and workmanship which caused the failure of the Warranted Parts for a period of two years from the date the engine is delivered to a retail purchaser. 3. No Charge Repair or replacement of any Warranted Part will be performed at no charge to the owner, including diagnostic labor which leads to the determination that a Warranted Part is defective, if the diagnostic work is performed at an Authorized B&S Service Dealer. For emissions warranty service contact your nearest Authorized B&S Service Dealer as listed in the Yellow Pages" under Engines, Gasoline," Gasoline Engines," Lawn Mowers," or similar category. 4. Claims and Coverage Exclusions Warranty claims shall be filed in accordance with the provisions of the B&S Engine Warranty Policy. Warranty coverage shall be excluded for failures of Warranted Parts which are not original B&S parts or because of abuse, neglect or improper maintenance as set forth in the B&S Engine Warranty Policy. B&S is not liable to cover failures of Warranted Parts caused by the use of add-on, non-original, or modified parts. 5. Maintenance Any Warranted Part which is not scheduled for replacement as required maintenance or which is scheduled only for regular inspection to the effect of repair or replace as necessary" shall be warranted as to defects for the warranty period.



[You're reading an excerpt. Click here to read official BRIGGS & STRATTON 110600 user guide](http://yourpdfguides.com/dref/3638578)  
<http://yourpdfguides.com/dref/3638578>



Any Warranted Part which is scheduled for replacement as required maintenance shall be warranted as to defects only for the period of time up to the first scheduled replacement for that part. Any replacement part that is equivalent in performance and durability may be used in the performance of any maintenance or repairs. The owner is responsible for the performance of all required maintenance, as defined in the B&S Operating and Maintenance Instructions. 6. Consequential Coverage Coverage hereunder shall extend to the failure of any engine components caused by the failure of any Warranted Part still under warranty. Look For Relevant Emissions Durability Period and Air Index Information On Your Engine Emission Label Engines that are certified to meet the California Air Resources Board (CARB) Tier 2 Emissions Standards must display information regarding the Emissions Durability Period and the Air Index. Briggs & Stratton makes this information available to the consumer on our emissions labels.

The engine emissions label will indicate certification information. The Emissions Durability Period describes the number of hours of actual running time for which the engine is certified to be emissions compliant, assuming proper maintenance in accordance with the Operating & Maintenance Instructions. The following categories are used: Moderate: Engine is certified to be emissions compliant for 125 hours of actual engine running time. Intermediate: Engine is certified to be emissions compliant for 250 hours of actual engine running time. Extended: Engine is certified to be emissions compliant for 500 hours of actual engine running time. For example, a typical walk-behind lawn mower is used 20 to 25 hours per year. Therefore, the Emissions Durability Period of an engine with an intermediate rating would equate to 10 to 12 years. Certain Briggs & Stratton engines will be certified to meet the United States Environmental Protection Agency (USEPA) Phase 2 emissions standards. For Phase 2 certified engines, the Emissions Compliance Period referred to on the Emissions Compliance label indicates the number of operating hours for which the engine has been shown to meet Federal emissions requirements. For engines less than 225 CC displacement Category C = 125 hours Category B = 250 hours Category A = 500 hours For engines of 225 CC or more displacement Category C = 250 hours Category B = 500 hours Category A = 1000 hours In the U.

S.A., the 120000 engines covered in this manual are certified by the California Air Resources Board to meet emissions standards for 50 hours. Such certification does not grant the purchaser, owner or operator of this engine any additional warranties with respect to the performance or operational life of this engine. This engine is warranted solely according to the product and emissions warranties stated elsewhere in this manual.

**5 BRIGGS & STRATTON ENGINE OWNER WARRANTY POLICY** Effective 12/06 Briggs & Stratton Corporation will repair or replace, free of charge, any part(s) of the engine that is defective in material or workmanship or both. Transportation charges on parts submitted for repair or replacement under this warranty must be borne by purchaser. This warranty is effective for and is subject to the time periods and conditions stated below. For warranty service, find the nearest Authorized Service Dealer in our dealer locator map at [www.briggsandstratton.com](http://www.briggsandstratton.com), or by calling 1-800-233-3723, or as listed in the Yellow Pages™. THERE IS NO OTHER EXPRESS WARRANTY. IMPLIED WARRANTIES, INCLUDING THOSE OF MERCHANTABILITY AND FITNESS FOR A PARTICULAR PURPOSE, ARE LIMITED TO ONE YEAR FROM PURCHASE, OR TO THE EXTENT PERMITTED BY LAW ANY AND ALL IMPLIED WARRANTIES ARE EXCLUDED. LIABILITY FOR INCIDENTAL OR CONSEQUENTIAL DAMAGES ARE EXCLUDED TO THE EXTENT EXCLUSION IS PERMITTED BY LAW. Some states or countries do not allow limitations on how long an implied warranty lasts, and some states or countries do not allow the exclusion or limitation of incidental or consequential damages, so the above limitation and exclusion may not apply to you. This warranty gives you specific legal rights and you may also have other rights which vary from state to state and country to country. LIMITED WARRANTY WARRANTY TERMS \*\* Brand / Product Type Vanguardt Extended Life Seriest, I / CR, Intek I / CR, Intek Prot Kerosene Fuel Operated Engines All Other Briggs & Stratton Engines Consumer Use 2 years 2 years 1 year 2 years Commercial Use 2 years 1 year 90 days 90 days \*\* Engines used on Home Standby Generator applications are warranted under consumer use only. This warranty does not apply to engines on equipment used for prime power in place of a utility. Engines used in competitive racing or on commercial or rental tracks are not warranted. The warranty period begins on the date of purchase by the first retail consumer or commercial end user, and continues for the period of time stated in the table above.

"Consumer use" means personal residential household use by a retail consumer. "Commercial use" means all other uses, including use for commercial, income producing or rental purposes. Once an engine has experienced commercial use, it shall thereafter be considered as a commercial use engine for purposes of this warranty. NO WARRANTY REGISTRATION IS NECESSARY TO OBTAIN WARRANTY ON BRIGGS & STRATTON PRODUCTS. SAVE YOUR PROOF OF PURCHASE RECEIPT. IF YOU DO NOT PROVIDE PROOF OF THE INITIAL PURCHASE DATE AT THE TIME WARRANTY SERVICE IS REQUESTED, THE MANUFACTURING DATE OF THE PRODUCT WILL BE USED TO DETERMINE THE WARRANTY PERIOD. ABOUT YOUR ENGINE WARRANTY Briggs & Stratton welcomes warranty repair and apologizes to you for being inconvenienced. Any Authorized Service Dealer may perform warranty repairs. Most warranty repairs are handled routinely, but sometimes requests for warranty service may not be appropriate. For example, warranty would not apply if engine damage occurred because of misuse, lack of routine maintenance, shipping, handling, warehousing or improper installation.

Similarly, warranty is void if the serial number of the engine has been removed or the engine has been altered or modified. If a customer differs with the decision of the Service Dealer, an investigation will be made to determine whether the warranty applies. Ask the Service Dealer to submit all supporting facts to his Distributor or the Factory for review. @@@@ Improper maintenance: The life of an engine depends upon the conditions under which it operates, and the care it receives. Some applications, such as tillers, pumps and rotary mowers, are very often used in dusty or dirty conditions, which can cause what appears to be premature wear.

Such wear, when caused by dirt, dust, spark plug cleaning grit, or other abrasive material that has entered the engine because of improper maintenance, is not covered by warranty. This warranty covers engine related defective material and/ or workmanship only, and not replacement or refund of the equipment to which the engine may be mounted.



[You're reading an excerpt. Click here to read official BRIGGS & STRATTON 110600 user guide](http://yourpdfguides.com/dref/3638578)  
<http://yourpdfguides.com/dref/3638578>

Nor does the warranty extend to repairs required because of: 1. PROBLEMS CAUSED BY PARTS THAT ARE NOT ORIGINAL BRIGGS & STRATTON PARTS. 2.

Equipment controls or installations that prevent starting, cause unsatisfactory engine performance, or shorten engine life. (Contact equipment manufacturer.) 3. Leaking carburetors, clogged fuel pipes, sticking valves, or other damage, caused by using contaminated or stale fuel. (Use clean, fresh, lead-free gasoline and Briggs & Stratton Fuel Stabilizer, Part No. 5041.) 4. Parts which are scored or broken because an engine was operated with insufficient or contaminated lubricating oil, or an incorrect grade of lubricating oil (check oil level daily or after every 8 hours of operation. Refill when necessary and change at recommended intervals.) OIL GARD may not shut down running engine.

Engine damage may occur if oil level is not properly maintained. Read Operating & Maintenance Instructions. 5. Repair or adjustment of associated parts or assemblies such as clutches, transmissions, remote controls, etc., which are not manufactured by Briggs & Stratton. 6. Damage or wear to parts caused by dirt, which entered the engine because of improper air cleaner maintenance, re-assembly, or use of a non-original air cleaner element or cartridge. (At recommended intervals, clean and re-oil 5,548,955 5,546,901 5,445,014 5,503,125 5,501,203 5,497,679 5,320,795 5,301,643 5,271,363 5,269,713 5,265,700 the Oil-Foam element or the foam pre-cleaner, and replace the cartridge.) Read Operating & Maintenance Instructions. 7.

Parts damaged by over-speeding, or overheating caused by grass, debris, or dirt, which plugs or clogs the cooling fins, or flywheel area, or damage caused by operating the engine in a confined area without sufficient ventilation. (Clean fins on the cylinder, cylinder head and flywheel at recommended intervals.)

Read Operating & Maintenance Instructions. 8. Engine or equipment parts broken by excessive vibration caused by a loose engine mounting, loose cutter blades, unbalanced blades or loose or unbalanced impellers, improper attachment of equipment to engine crankshaft, over-speeding or other abuse in operation.

9. A bent or broken crankshaft, caused by striking a solid object with the cutter blade of a rotary lawn mower, or excessive v-belt tightness. 10. Routine tune-up or adjustment of the engine. 11.

Engine or engine component failure, i.e., combustion chamber, valves, valve seats, valve guides, or burned starter motor windings, caused by the use of alternate fuels such as, liquified petroleum, natural gas, altered gasolines, etc. Warranty is available only through service dealers which have been authorized by Briggs & Stratton Corporation. your nearest Authorized Service Dealer is listed in the Yellow Pages™ of your telephone directory under Engines,

Gasoline" or Gasoline Engines," Lawn Mowers," or similar category. 5,243,878 5,235,943 5,234,038 5,228,487 5,197,426 5,197,425 5,197,422 5,191,864 5,188,069 5,186,142 5,150,674 5,138,996 5,086,890 5,070,829 5,058,544 5,040,644 5,009,208 4,996,956 4,977,879 4,977,877 4,971,219 4,895,119 4,875,448 4,819,593 4,720,638 4,719,682 4,633,556 4,630,498 4,522,080 4,520,288 4,512,499 4,453,507 4,430,984 D 476,629 D 457,891 D 368,187 D 375,963 D 309,457 D 372,871 D 361,771 D 356,951 D 309,457 D 308,872 D 308,871 Briggs & Stratton Engines Are Made Under One Or More Of The Following

Patents: Design D-247,177 (Other Patents Pending) 5,803,035 6,012,420 6,145,487 6,325,036 6,520,141 6,691,683 5,765,713 5,992,367 6,142,257 6,311,663 6,495,267 6,647,942 5,732,555 5,904,124 6,135,426 6,284,123 6,494,175 6,622,683 5,645,025 5,894,715 6,116,212 6,263,852 6,472,790 6,615,787 5,642,701 5,887,678 6,105,548 6,260,529 6,460,502 6,617,725 5,628,352 5,852,951 6,347,614 6,242,828 6,456,515 6,603,227 5,619,845 5,843,345 6,082,323 6,239,709 6,382,166 6,595,897 5,606,948 5,823,153 6,077,063 6,237,555 6,369,532 6,595,176 5,606,851 5,819,513 6,064,027 6,230,678 6,356,003 6,584,964 5,605,130 5,813,384 6,040,767 6,213,083 6,349,688 6,557,833 5,497,679 5,809,958 6,014,808 6,202,616 6,347,614 6,542,074 6 Fig. 7 Fig. 8 Fig. 9 Fig. 10 .



[You're reading an excerpt. Click here to read official BRIGGS & STRATTON 110600 user guide](http://yourpdfguides.com/dref/3638578)  
<http://yourpdfguides.com/dref/3638578>